

Clarke®

American Sanders®

American 12

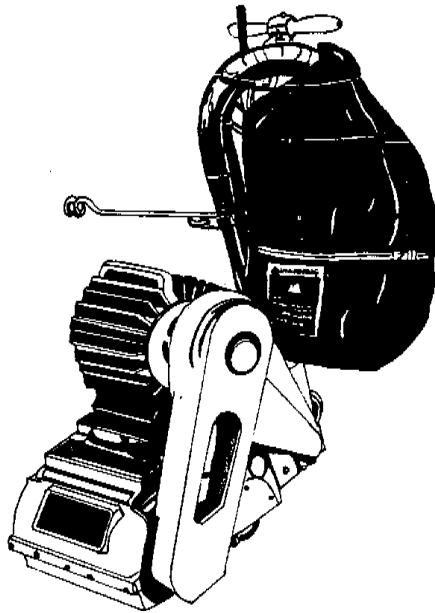

Operator's Manual

Models: 07044C, 07108A, 07120A, 07049C, 07109A

READ THIS BOOK

This book has important information for the use and safe operation of this machine. Failure to read this book prior to operating or attempting any service or maintenance procedure to your Clarke American Sanders machine could result in injury to you or to other personnel; damage to the machine or to other property could occur as well. You must have training in the operation of this machine before using it. If operator(s) cannot read this manual, have it explained fully before attempting to operate this machine.

Si Ud. o sus operadores no pueden leer el Inglés, se hagan explicar este manual completamente antes de tratar el manejo o servicio de esta máquina.

All directions given in this book are as seen from the operator's position at the rear of the machine.

Contents of this Book

| | |
|----------------------------------------------|----|
| Operator Safety Instructions..... | 3 |
| Introduction and Machine Specifications..... | 5 |
| 230V Electrical Connection Instructions..... | 6 |
| How to Transport the Machine..... | 7 |
| Machine Set-Up..... | 8 |
| How to Operate the Machine..... | 10 |
| Sanding Cuts and Sandpaper | 12 |
| Sander Adjustment Procedures..... | 14 |
| Routine Maintenance..... | 16 |
| Troubleshooting..... | 17 |
| SECTION II - Parts and Service Manual | |
| Assembly Drawing #1..... | 20 |
| Assembly Parts List #1..... | 21 |
| Assembly Drawing #2..... | 22 |
| Assembly Parts List #2..... | 23 |
| Assembly Drawing #3..... | 24 |
| Assembly Parts List #3..... | 25 |
| Accessories Drawing & Parts List..... | 26 |
| Wiring Diagram..... | 27 |
| Chatter-Wave Prevention | 28 |

WARNING!

The Products sold with this Manual contain or may contain chemicals that are known to certain governments (such as the State of California, as identified in its Proposition 65 Regulatory Warning Law) to cause cancer, birth defects or other reproductive harm. In certain locations (including the State of California) purchasers of these Products that place them in service at an employment job site or a publicly accessible space are required by regulation to make certain notices, warnings or disclosures regarding the chemicals that are or may be contained in the Products at or about such work sites. It is the purchaser's responsibility to know the content of, and to comply with, any laws and regulations relating to the use of these Products in such environments. The Manufacturer disclaims any responsibility to advise purchasers of any specific requirements that may be applicable to the use of the Products in such environments.

OPERATOR SAFETY INSTRUCTIONS



WARNING



AVERTISSEMENT



ADVERTENCIA

DANGER means: Severe bodily injury or death can occur to you or other personnel if the **DANGER** statements found on this machine or in this Operator's Manual are ignored or are not adhered to. Read and observe all **DANGER** statements found in this Operator's Manual and on your machine.

WARNING means: Injury can occur to you or to other personnel if the **WARNING** statements found on your machine or in this Operator's Manual are ignored or are not adhered to. Read and observe all **WARNING** statements found in this Operator's Manual and on your machine.

CAUTION means: Damage can occur to the machine or to other property if the **CAUTION** statements found on your machine or in this Operator's Manual are ignored or are not adhered to. Read and observe all **CAUTION** statements found in this Operator's Manual and on your machine.



DANGER:



Failure to read the Operator's Manual before operating or servicing this sanding equipment could result in injury to the operator or to bystanders and could cause damage to the equipment. Read and observe all safety statements found in this manual and on the sanding equipment. Make sure all labels, decals, warnings, cautions and instructions are fastened to the equipment. Replace any that are damaged or missing. You must have training in the operation of this equipment before using it. **If the operator is unable to read this manual, have it explained fully before they attempt to use this equipment.**



DANGER:



Sanding/finishing wood floors can create an environment that can be explosive. The following safety procedures must be adhered to:

- Cigarette lighters, pilot lights and any other source of ignition can create an explosion when active during a sanding session. All sources of ignition should be extinguished or removed entirely if possible from the work area.
- Work areas that are poorly ventilated can create an explosive environment when certain combustible materials are in the atmosphere, i.e., solvents, thinners, alcohol, fuels, certain finishes, wood dust and other combustible materials. Floor sanding equipment can cause flammable material and vapors to burn. Read the manufacturer's label on all chemicals used to determine combustibility. Keep the work area well ventilated.
- Spontaneous combustion or an explosion can occur when working with sanding dust. The sanding dust can self-ignite and cause injury or damage. Sanding dust should be disposed of properly. Always empty the sanding dust into a metal container that is located outside of any building(s).
- Remove the contents of the dust bag when the bag is 1/3 full. Remove the contents of the dust bag each time you finish using the equipment. Never leave a dust bag unattended with sanding dust in it.
- Do not empty the contents of the dust bag into a fire.
- Hitting a nail while sanding can cause sparks and create an explosion or fire. Always use a hammer and punch to countersink all nails before sanding floors.

**DANGER:**

Operating partially assembled sanding equipment could result in injury to the operator or bystander and could cause damage to the equipment or to other property.

- Do not operate this equipment unless it is fully assembled and all guards, doors and covers are secured.
- Keep all fasteners tight.
- Keep all adjustments within manufacturer's specifications.

**DANGER:**

Moving parts on this sanding equipment can cause injury to the operator or bystanders.



- Keep hands, feet and loose clothing away from all moving parts.
- Do not change or adjust the abrasive while the sanding equipment is running.
- Do not service the sanding equipment while it is running.

**DANGER:**

This sanding equipment requires a supply of electricity. Improper use could result in electrical shock or fire.



- Connect only to an electrical source matching what is shown on the equipment nameplate.
- Do not use this sanding equipment on an ungrounded electrical circuit. Consult an electrician if you suspect the circuit is not properly grounded.
- Do not use this sanding equipment with a damaged electrical cord. Inspect before each use.
- Avoid striking the electrical cord with the abrasive. Always lift the electrical cord over the sanding equipment.
- Do not use the electrical cord to move the sanding equipment.
- Disconnect the electrical source before servicing this equipment.

**WARNING:**

In the event of a bag fire, injury can occur to the operator if the operator is tied or strapped to equipment. Use operating belt properly (follow procedure on page 11).

**WARNING:**

Injury to the operator or bystander can occur if protective gear is not worn while sanding. Always use eye, ear, and respiratory protection while performing any sanding operation.

**WARNING:**

Bodily injury could occur if power is applied to the equipment with the power switch already in the "ON" position. Always check to assure that the power switch is in the "OFF" position before connecting power supply.

**CAUTION:**

Maintenance and repairs performed by unauthorized personnel could result in damage or injury. Maintenance and repairs performed by unauthorized personnel will void your warranty. Servicing of this unit must always be referred to an authorized Clarke American Sanders distributor.

**CAUTION:**

Use of this equipment to move other objects or to climb on could result in injury or damage. Do not use this equipment as a step or furniture. Do not ride on this equipment.

**CAUTION:**

Damage could occur to the equipment if not properly kept in a dry building for storage. Store the equipment in a dry building.

**CAUTION:**

The equipment is heavy. When transporting the equipment, remove the motor. Get help to lift the equipment and motor.

**CAUTION:**

Serious damage to the floor can occur if the sanding equipment is left running in one spot while the sanding drum is in contact with the floor. To avoid damage to the floor, feather cut in at a normal sanding rate. Do not dwell while lowering or raising the contact wheel. Always sand at a constant rate.

Introduction and Machine Specifications

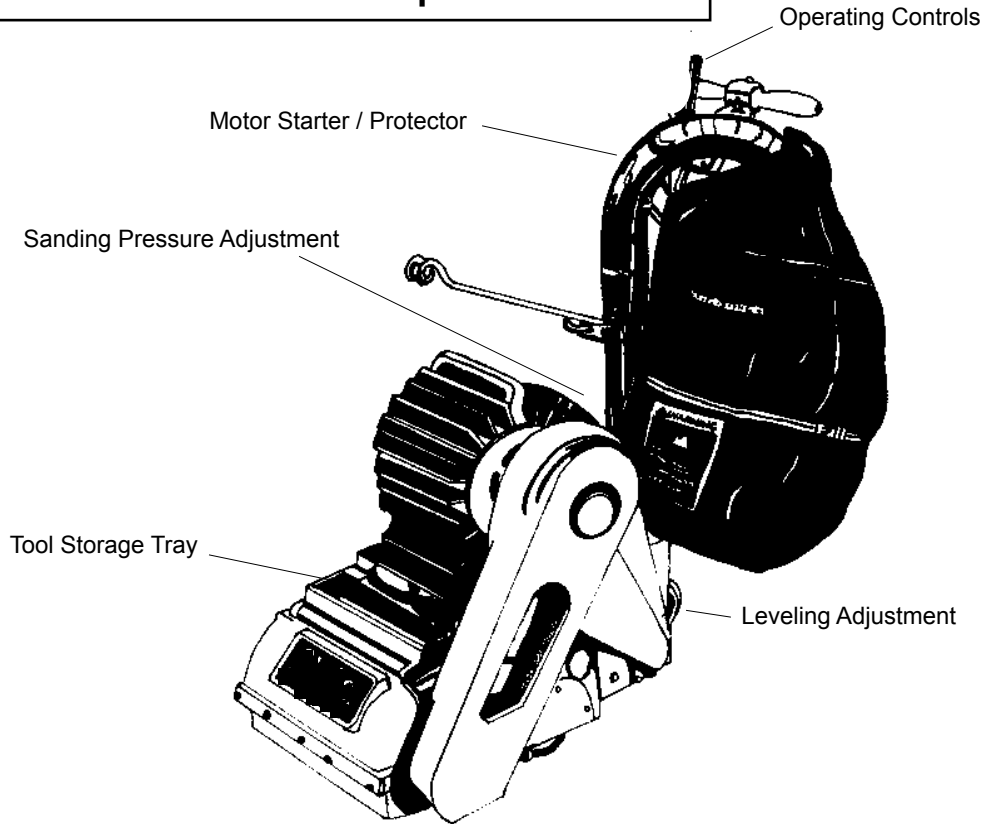

| MODEL | 07108A / (07044C) | 07109A / (07049C) | 07120A |
|--------------------------|-------------------------------------|-------------------------------------|-------------------------------------|
| Electrical Requirements | ~208-240V 60 Hz | ~220-240V 50 Hz | ~220-240V 50 Hz |
| Amperage | 15.7 | 11.8 | 11.8 |
| Sound Emission (Lpm) | 83.0 dB(A) | 79.4 dB(A) | 79.4 dB(A) |
| Vibration | <.30 in/s | < 2.5 m/s ² | < 2.5 m/s ² |
| Contact Wheel Rate (rpm) | 2000/2400 | 1670/2000 | 1670/2000 |
| Abrasive Rate | 3800/4560 ft/min | 970/1160 m/min | 970/1160 m/min |
| Fan Flow Rate | 280 CFM | 110 liters/s | 110 liters/s |
| Abrasive Sheet Size | 12" x 26 1/8" | 305mm x 664mm | 305mm x 664mm |
| Motor | 4 Hp Continuous | 2.2 kW Continuous | 2.2 kW Continuous |
| Overload Protection | Magnetic Circuit Breaker | Magnetic Circuit Breaker | 13 A Fuse |
| Operating Controls | Adjustable Lever/Grip | Adjustable Lever/Grip | Adjustable Lever/Grip |
| Leveling Controls | Externally Adjustable | Externally Adjustable | Externally Adjustable |
| Electrical Cable | 100' 10-3 SJO with L6-20P Plug | 100' 12-3 SJO with AU2-15P Plug | 15m HO7RN-F3GI .5 with UK1-13P Plug |
| Operating Wheels | 80 Durometer Clear Urethane (Steel) | 80 Durometer Clear Urethane (Steel) | 80 Durometer Clear Urethane |
| Weight | 240 lbs. | 204 lbs. | 92.7 kg |
| Dimensions | 40½ x 15 x 36 3/4 | 40½ x 15 x 36 3/4 | 103cm x 38cm x 93cm |

CAUTION: Your equipment may be inappropriate on some installations. Some softer woods used in flooring cannot support the pressure created by hard wheels.

Always consult with the flooring manufacturer on the proper installation, preparation, and finishing of their product. Determine suitability of your equipment in preparing the product.

230V Electrical Connection Instructions

CAUTION: This machine will operate only on AC frequency and on electrical voltage shown on the equipment nameplate. Make sure you have the correct frequency and voltage before connecting the power cord to an outlet. See the example in figure 1.

This machine must be connected to an electrical source with an earthing conductor in order to protect the operator from electric shock. This machine has an approved power cord with three conductors as well as a plug with three terminals. Connect the plug to a matching receptacle.

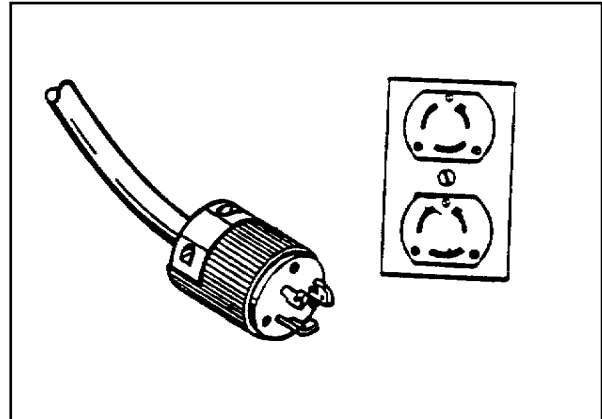

Figure 1

DANGER: Electrocutation could occur if the machine is exposed to water or rain. Keep the machine in a dry building.

DANGER: Electrocutation could occur if machine is not connected to an electrical source with an earthing conductor. To prevent possible electric shock, use an electrical cord with an earthing conductor and connect it to a matching electrical source. For maximum protection against electrical shock, use a circuit that is protected by a ground fault circuit interrupter. Consult your electrical contractor.

DANGER: Electrocutation could occur if the machine is used with a damaged plug or power cord. If the cords or plugs are worn or damaged in any way, have them replaced by an authorized service person or electrician.

Extension Cords

Use only an approved three-pronged extension cord with two main conductors and one earthing conductor. This machine is equipped with a power cord. When greater range is needed follow the table below to determine cable gauge of additional footage. Refer to the chart to the right for extension cord information.

Feet/Wire Gauge (Stranded Copper)

| Source Voltage | 0 - 100' | 100 - 250' |
|----------------|----------|---------------------|
| 208 | 6 | Use Voltage Booster |
| 230 | 10 | 8 |

If motor appears to labor or takes a considerable longer time to come up to speed reduce sanding pressure.

How to Transport the Machine

⚠ WARNING: The machine is heavy. Remove the motor from the machine before transporting. Get help loading the machine and motor.

To transport the machine, follow this procedure:

1. Make sure the power cable is disconnected from the electrical outlet.
2. Disconnect the handle plug connection. See figure 1.
3. Remove the belt cover.
4. Remove the fan belt.
5. Loosen the motor bolt. Using the $\frac{3}{4}$ " wrench, turn the motor bolt counterclockwise. See figure 2.
6. Slide the motor forward.
7. Remove the drive belt.
8. Remove the motor from the chassis.

To re-assemble the machine after transporting, follow this procedure:

1. Reposition motor on chassis.
2. Install the drum belt. Slide the motor back until adequate tension is achieved in belt.

⚠ CAUTION: To prevent damage to the floor surface, make sure the drive belt is tight.

3. Resecure the motor to the chassis.
4. Install the fan belt.
5. Install the belt cover.
6. Reconnect the handle plug.

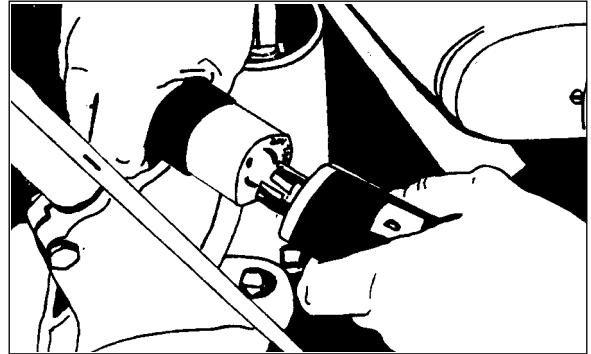

Figure 1

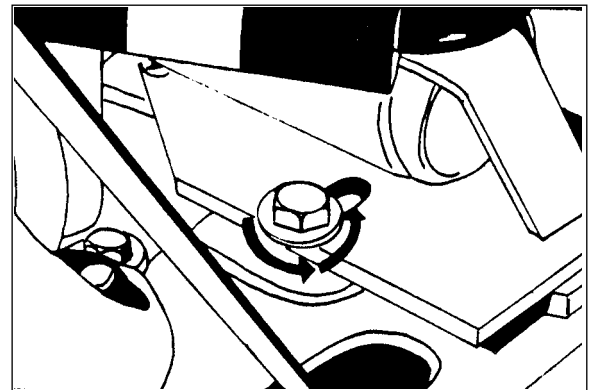

Figure 2

Machine Set-Up

To set-up your machine follow this procedure:

1. Familiarize yourself with the machine and read all danger, warning and caution statements. Make sure all operators of this machine have read this Owner's Manual. If they cannot read English, have the manual explained fully before allowing anyone to operate the sander.
2. Locate the power supply. The receptacle should be compatible with the plug. The receptacle must be grounded and must be fused (30 amp) to avoid an electrical hazard.
3. Clip the dust bag to the elbow. Cross the strings on the dust bag and draw tight over the flare on the elbow. Wrap the string around the elbow and secure.
4. Wind the power cord through the cable arm. Keep the power cord out of path of equipment.

How To Install The Abrasive



WARNING: Disconnect power before changing abrasive.

To install the abrasive, follow this procedure:

1. Prepare abrasive with template supplied.
2. Place backing of abrasive on the template. The template is marked "This Side Up." Make sure the marked side of the template is facing up.
3. Cut the abrasive to the exact length of the template.
4. Align one edge of the abrasive with a notch in the template.
5. Fold the other end of the abrasive over the end of the template and crease.
6. Repeat steps 4 and 5 for remaining notch.
7. Lift the drum cover.

8. Put the smooth side of the abrasive against the sanding drum.
9. Put one end of the abrasive against the sanding drum slot (1). See figure 3.
10. Turn the drum one revolution. Put the other end of the abrasive in the drum slot (2). See figure 3.
11. Tighten the abrasive.

To tighten the abrasive, follow this procedure:

1. The end wrenches are given with the machine. Put a wrench around the nut at each end of the drum (1). See figure 4.
2. Make sure the flat sides of the nuts are parallel with the drum slot.
3. Turn the wrenches the opposite rotation until the abrasive is tight against the drum (2). See figure 4.

12. Remove the end wrenches.
13. Close the cover.

NOTE: When using #4 or 4½ grit abrasive, remove the large grains from the folded ends. To remove the grains, rub the folded ends together.

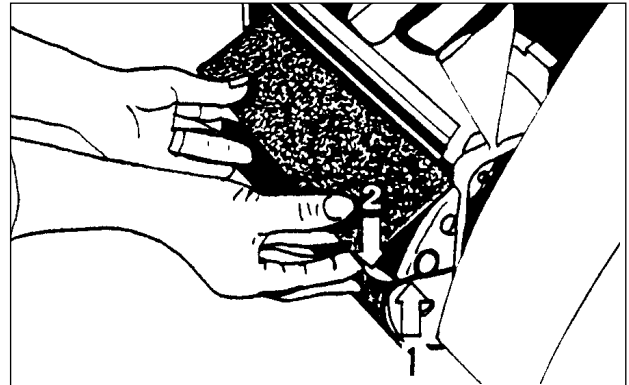

Figure 3

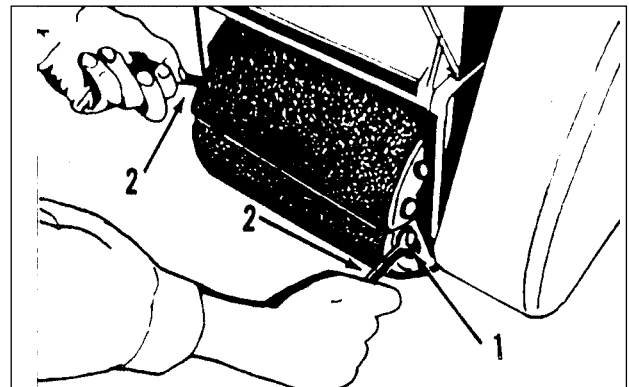





Figure 4

How to Operate the Machine

 **DANGER:** Sanding/finishing wood floors can create an environment that can be explosive. Cigarette lighters, pilot lights and any other source of ignition can create an explosion when active during a sanding session. All sources of ignition should be extinguished or removed entirely if possible from the work area.

 **DANGER:** Work areas that are poorly ventilated can create an explosive environment when certain combustible materials are in the atmosphere, i.e., solvents, thinners, alcohol, fuels, certain finishes, wood dust and other combustible materials. Floor sanding machines can cause flammable material and vapors to ignite. Read the manufacturer's label on all chemicals used to determine combustibility. Keep the work area well ventilated.

 **DANGER:** Sanding dust can spontaneously ignite and cause an injury or damage. Sanding dust should be disposed of properly. Always empty the sanding dust into a metal container. Remove the contents of the dust bag when the bag is 1/3 full.

 **DANGER:** Sanding dust can spontaneously ignite and cause an injury or damage. Remove the contents of the dust bag each time you finish using the machine. Always dispose of the dust in a metal container located outside of the building. Never leave a dust bag unattended with sanding dust in it. Do not empty the contents of the dust bag into a fire.

 **DANGER:** Hitting a nail while sanding can cause sparks and create an explosion or fire. Always use a hammer and punch to countersink all nails before sanding floors.

To operate the machine follow this procedure:

1. Install the operator's belt as follows:
 - a. Position the operator's belt around waist.
 - b. Cross the straps at the waist. See figure 5.
 - c. Slide the belt loop end over the handle on the control lever side. Adjust the length as needed.
 - d. Wrap the remaining strap around the opposite side of the handle and hold it in place with your hand.

⚠ WARNING: Should quick release of the machine be necessary, serious operator injury could occur if the operator has tied the loose end of the operator's belt strap to the machine. Always position the strap so that you can let go and get away quick in case of bag fire or explosion.

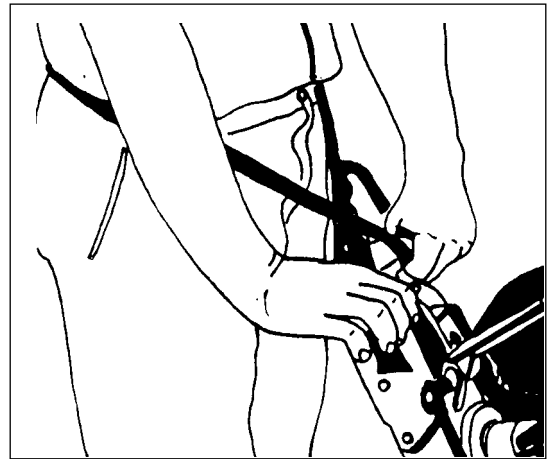
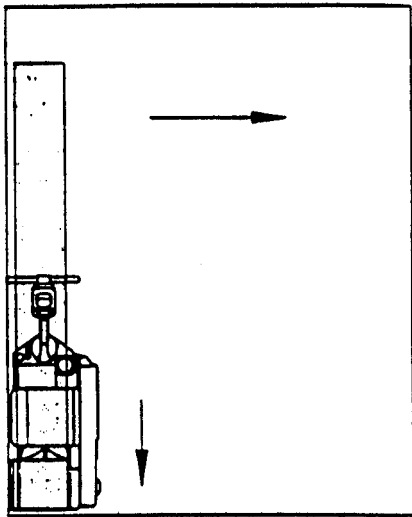

Figure 5

2. Put the On/Off switch into the "ON" position.

⚠ DANGER: Serious damage can occur to the floor surface if the machine is not in motion while the contact wheel is running on the floor surface. To prevent damage to the surface, make sure the machine is always moving when the contact wheel is in contact with the floor.

3. Work right to left. For each forward pass, move the machine 4" over the pass you have just finished. Retrace your reverse path without overlapping. See figure 6.
4. Feather-cut in by easing the contact wheel down onto the surface with the control lever while the sander is in motion.
5. When contact wheel is fully engaged with the surface, gradually adjust your pace for adequate finish removal. Keep sander in motion while the contact wheel is engaged with the surface or dwell marks will occur.
6. Move the machine in the direction of the grain in the wood whenever it is possible. Sand the surface at a constant pace.
7. Gradually feather-cut out at the termination point (the end of your pass) by easing the contact wheel up with the control lever. Stagger the termination points for a better blend when edging.
8. Empty dust bag whenever it is 1/3 full. Never leave a dust bag unattended with sanding dust in it. Sanding dust can spontaneously ignite and cause a fire or explosion. Empty dust into a metal container located **outside of the building**.



A. First pass forward, right to left.

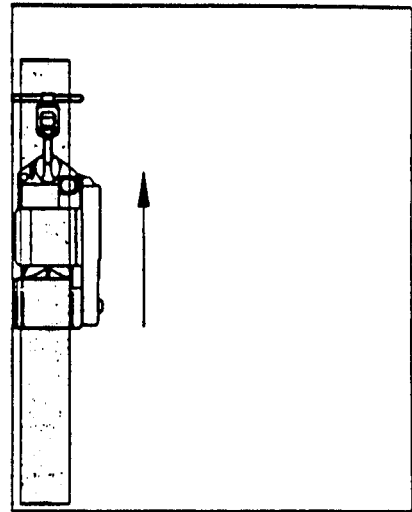

B. First pass reverse, retrace same path.

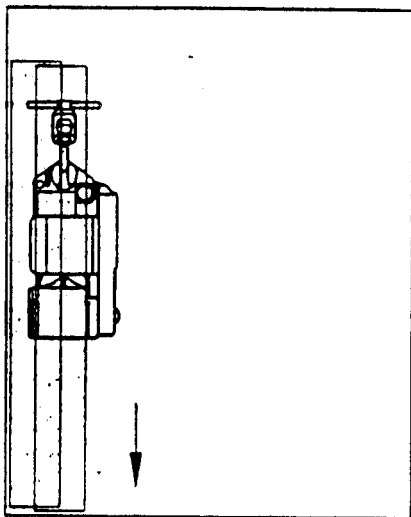

C. Second pass forward, overlap 1/2 the drum width.

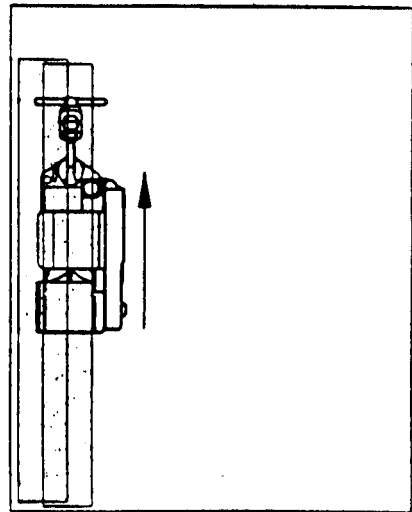

D. Second pass reverse, retrace second path forward, etc....for the entire room

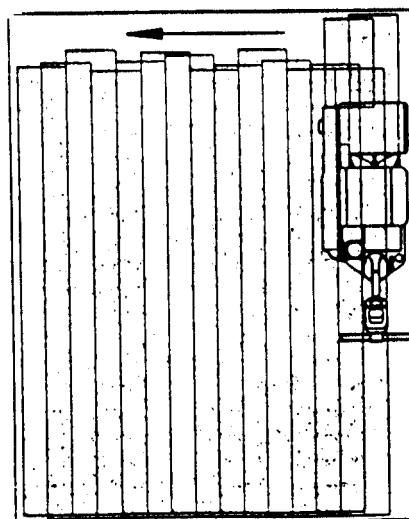

E. Work the remaining unsanded floor in the same fashion, right to left.

Figure 6

Sanding Cuts and Sandpaper

Initial Cut

The purpose of the initial cut is to remove old finish and gross imperfections on the floor surface. The sanding equipment should be adjusted to heavy sanding pressure setting and a coarse abrasive should be used. If the surface is severely damaged by deep scratches, pre-existing dwell marks, uneven planks, etc., it may be necessary to sand across or diagonally to the grain to restore evenness to the surface. If these conditions are not present, the initial cut should be done in the direction of the grain.

If glazing, loading, or burning takes place immediately into an initial cut, select a coarser abrasive. If this should occur during an initial cut, the abrasive has dulled and must be replaced.

Final Cuts

The purpose of a finishing cut is to remove the scratches produced during the initial cut. Use a fine (60 - 80 grit) grain abrasive and a reduced sanding pressure setting.

If the surface remains rough after a finishing cut, it may be necessary to use an even finer grain of abrasive (80 - 100 grit). Care should be taken in selecting the grit size of the abrasive. A very fine grain will close the pores on a wood floor making admission of a stain difficult.

If glazing or burning should occur immediately into a finishing cut, reduce the sanding pressure. If it should occur during a finishing cut, the abrasive has dulled and must be replaced.

| Abrasive Bulk Roll | | |
|-----------------------------------------------------------------|--------------------------------------------------------------------------------------------------------------------|--------------------------------------|
| Note: All part numbers listed are for 12" x 50' (30.5 cm x 18m) | | |
| Grain | Use | Part No. |
| 12 grit 16 grit 20 grit 24 grit | For removing gross imperfections and restore evenness to old flooring. To remove build-up of paints and varnishes. | 945516 945517 945518 945519 |
| 30 grit 36 grit | For first sanding of new flooring (maple, oak). For removing minor imperfections and finishes from old flooring. | 945520 945521 |
| 40 grit | For first sanding of new flooring (oak, walnut). For removing minor imperfections and finishes from old flooring. | 945522 |
| 50 grit | For first sanding of new flooring (cedar, pine, fir) For clean-up of 16 grit. | 945533 |
| 60 grit | For clean-up from initial cut 36 - 40 grit. | 945544 |
| 80 grit | For final sanding of certain hardwoods. For clean-up of initial cuts (50 grit). | 945545 |
| 100 grit | For final sanding of certain hardwoods where a smooth surface is desired. | 945546 |
| 120 grit | For final sanding of certain conifers. | 945547 |
| 150 grit | For final sanding of certain conifers where a smooth surface is desired. | 945548 |
| 180 grit | For surface roughing between coats of finish. | 945549 |

Sander Adjustment Procedures



DANGER: Electrocutation could occur if maintenance and repairs are performed on a unit that is not properly disconnected from the power source. Disconnect the power supply before attempting any maintenance or service.



DANGER: Moving parts of this machine can cause serious injury and/or damage. Keep hands, feet and loose clothing away from all moving parts of the sander.

Sanding Pressure

To adjust the sanding pressure follow this procedure:

1. Screw the sanding pressure knob down to increase the sanding pressure when making the roughing in cut.
2. Screw the sanding pressure knob up to decrease the sanding pressure when making the finishing cut.

Drum Rates

The machine can be operated at two rates. To change the speed of the drum, follow this procedure:

1. Remove the belt cover.
2. Remove the fan belt.
3. Loosen the motor bolt.
4. Slide the motor forward.
5. For high drum rates, install drive belt in larger diameter of the grooves available on the motor pulley and in the smaller diameter of the two grooves available on the drum pulley. For lower rates, install drive belt in smaller diameter of the grooves available on the motor pulley and in the larger diameter of the two grooves available on the drum pulley.
6. Tighten belt and secure motor to chassis.
7. Install the fan belt.
8. Install the belt guard.

Leveling

If the sanding drum is out of adjustment, follow this procedure:

1. Remove the belt cover.
2. Loosen the eccentric lock screw. Using the 7/16" wrench, turn the eccentric lock screw (1) counter-clockwise. See figure 7.
3. To raise or lower the drum, turn the eccentric (2). See figure 7.
4. Tighten the eccentric lock screw. To tighten the eccentric lock screw, turn the screw clockwise.
5. Install the belt cover.

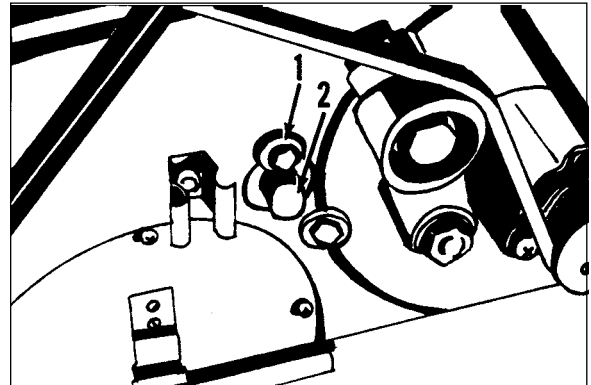

Figure 7

How to Lubricate the Wheel Pivots

NOTE: The wheel pivots must be lubricated after every 25 hours of use.

To lubricate the wheel pivots, follow this procedure:

1. Put the machine on its side.
2. Lubricate the pivots. The pivots are behind the truck wheels. See figure 8.
3. Put the machine on its wheels.

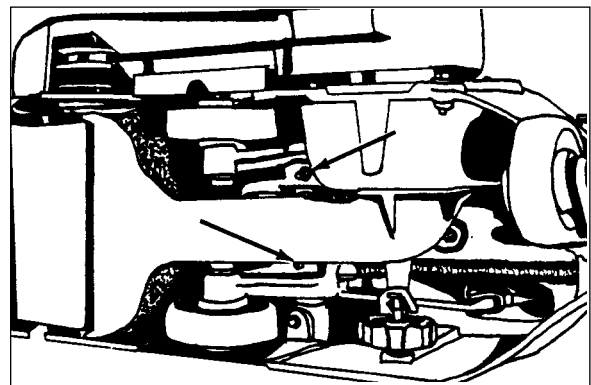

Figure 8

Operating Control

To **increase** the travel or extend the reach on the grip control follow this procedure:

1. Loosen the locknut on the control rod. See figure 9.
2. Screw the control rod adjuster **in** until the desired reach is found.
3. Tighten the locknut.

To **decrease** the travel or reduce the reach on the grip control follow this procedure:

1. Loosen the locknut on the control rod. See figure 9.
2. Screw the control rod adjuster **out** until desired reach is found.
3. Tighten the locknut.

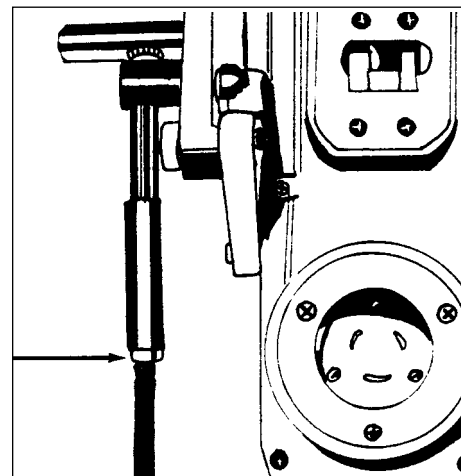

Figure 9

Routine Maintenance

The following items need to be periodically inspected and maintained to keep your sander in good working condition.

Wheels

Periodically remove the debris from the truck and caster wheels. Debris can cause waves on a sanded surface. Lubricate truck mechanism every 25 hours of use. The machine is equipped with lubrication fittings and are located on shaft supporting mechanism.

Dust Bag

Remove the dust bag from the machine and shake it thoroughly to remove the sanding dust from the dust bag. Turn the dust bag inside out and machine wash in cold water to prevent pore blockage and loss of dust recovery.

Drive Belt

Periodically check the drive belt tension.

Bearings

Periodically check the bearings for wear or damage according to the following schedule:

| | |
|---------------------|---------------------|
| <i>Idler pulley</i> | after 1st 1500 hrs. |
| <i>Fan shaft</i> | after 1st 2500 hrs. |
| <i>Arbor shaft</i> | after 1st 5000 hrs. |
| <i>Motor shaft</i> | after 1st 5000 hrs. |

Troubleshooting

| PROBLEM | CAUSE | ACTION |
|-------------------------------------------------------------------|----------------------------------------------------------------------------------------------------------------------------------------------------------------------------------------|-------------------------------------------------------------------------------------------------------------------------------------------------------------------------------------------------------------------------------------------------------------------------------------------------------------------------------------------------------------------------------------------------------------|
| Drive belts slip. | Insufficient tension. Worn belts. | Tension drive belt. (Squeaking or squealing sound) Replace belts. |
| Squealing, growling or grinding noise coming from machine. | Damaged and/or worn bearing. | Remove drive belts, rotate arbor motor, fan, shafts and idler pulley to locate dragging or rough bearing. Contact an authorized Clarke American Sanders dealer. |
| Dust pick-up is poor. | Dust bag is over 1/3 full. Dust bag is dirty. Dust chute is obstructed. | Empty contents of bag. Shake debris from bag and wash. Remove fan cover and clear throat. |
| Motor will not start. | Defective motor starter. Defective start capacitor. Defective electronic start switch. Low voltage from poor connection. Defective motor. No power. | Contact an authorized Clarke American Sanders dealer. Contact an authorized Clarke American Sanders dealer. Contact an authorized Clarke American Sanders dealer. Contact an authorized Clarke American Sanders dealer. Contact an authorized Clarke American Sanders dealer. Contact an authorized Clarke American Sanders dealer. Check power supply and connections. |
| Motor runs sluggishly. | Low voltage from excessive footage, undersized extension cord, or poor connection. Defective run capacitor. Defective motor. | Locate power source nearer to work site. Decrease sanding pressure. Contact an authorized Clarke American Sanders dealer. Contact an authorized Clarke American Sanders dealer. |
| Motor starter trips/repeatedly | Excessive load. Defective electronic start switch. Defective motor starter. Low voltage from poor connection. Defective motor Defective capacitor. | Contact an authorized Clarke American Sanders dealer. Contact an authorized Clarke American Sanders dealer. Contact an authorized Clarke American Sanders dealer. Contact an authorized Clarke American Sanders dealer. Contact an authorized Clarke American Sanders dealer. Contact an authorized Clarke American Sanders dealer. Contact an authorized Clarke American Sanders dealer. |
| Uneven cut. | Leveling out of adjustment. | Readjust leveling. |
| Burning or glazing. | Dull abrasive. Excessive sanding pressure. Too fine of an abrasive. | Replace abrasive. Decrease sanding pressure setting. Use coarser abrasive. |
| Slow cutting. | Dull abrasive. Too fine of an abrasive. Insufficient sanding pressure. | Replace abrasive. Use a coarser abrasive. Increase sanding pressure setting. |
| Waves on sanded surface. | Debris on wheel. Flat spot on tire(s). | Remove and clean wheels. Replace tires. |
| Chatter marks on sanded | Drum out of round. Surface (close evenly spaced) Drum vibration. | Contact an authorized Clarke American Sanders dealer or replace the drum. Change shim combination. Remove debris from surface or ends of drum. |

Clarke[®]

American Sanders

American
12
Section II
Parts and Service Manual

(78150D)

**Clarke®
American Sanders**

**Model American 12 Floor Sander
Drawing #1 Handle Assembly 5/06**

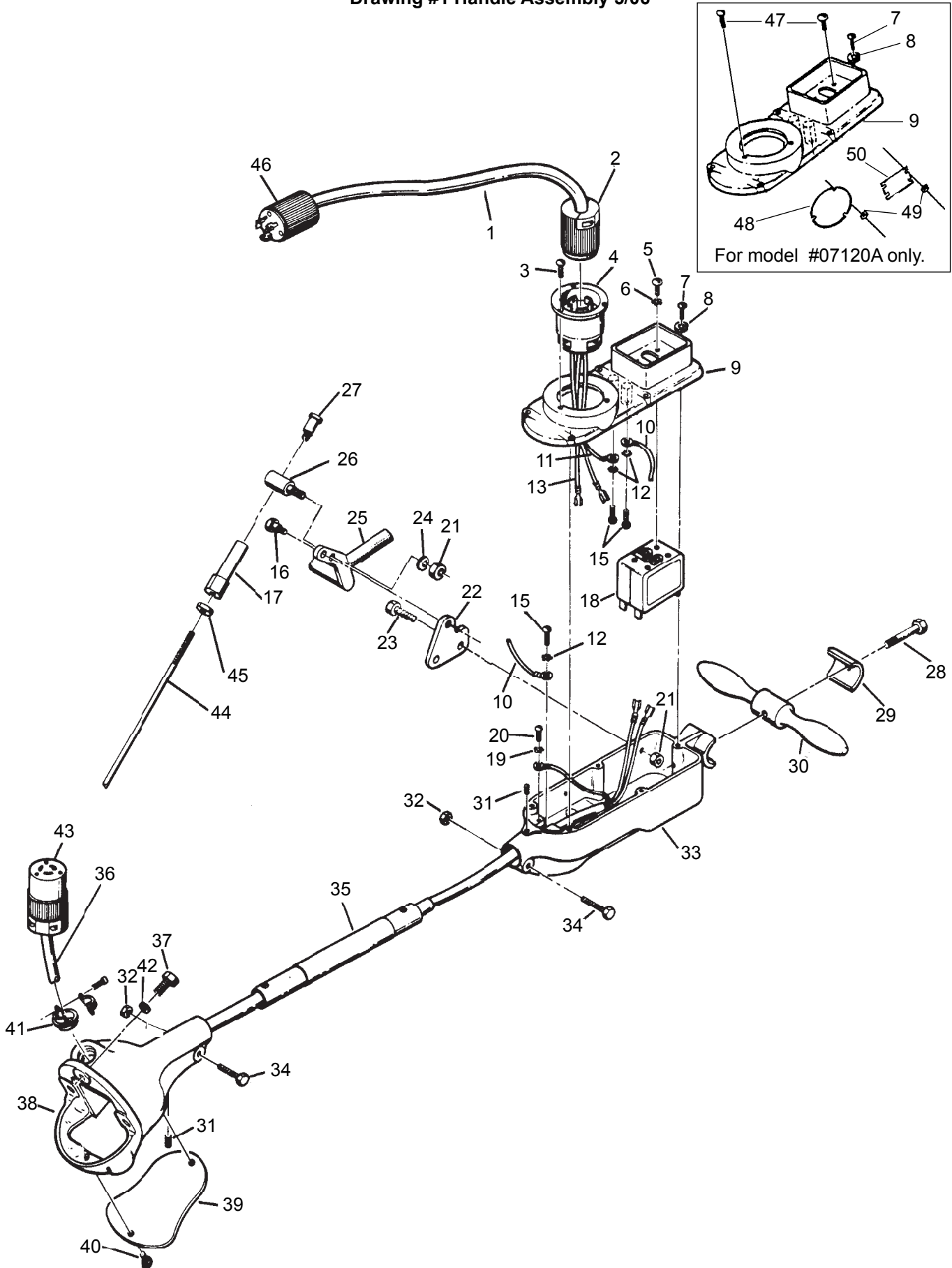

**Clarke®
American Sanders®**

**Model American 12 Floor Sander
Parts List #1 Handle Assembly 5/06**

| Ref No. | Part No | Description | Qty |
|---------|----------|---------------------------------|-----|
| 1 | Ref. | Cord Assembly | 1 |
| 2 | 41706A | Connector (NEMA) | 1 |
| 3 | 962065 | Screw - 8-32 x ¼ Pn St Mach | 3 |
| 4 | 43501A | Inlet - 20A, 250V | 1 |
| 5 | 85313C | Screw - 6-32 x ¼ Pn St Mach | 4 |
| 6 | 980607 | Washer - #1106 Shakeproof | 4 |
| 7 | 962794 | Screw - 10-24 x 1 Pn St | 5 |
| 8 | 980650 | Washer - 3/16 Lock | 5 |
| 9 | 22127C | Cover - Switch Box | 1 |
| 10 | 48901A | Wire Ass'y - Green | 1 |
| 11 | 48900A | Wire Assembly - Ground | 1 |
| 12 | 980699 | Washer - #1210 Shakeproof | 3 |
| 13 | 49023A | Wire Assembly Black | 2 |
| 15 | 962015 | Screw - 10-24 x 3/8 | 3 |
| 16 | 80022A | Bolt ½ x 5/8 | 1 |
| 17 | 67129A | Adjuster Control Rod | 1 |
| 18 | 41411A | Switch - Circuit Breaker | 1 |
| 19 | 980603 | Washer #8 Shakeproof | 1 |
| 20 | 85833A | Screw, #10-32 Ground | 1 |
| 21 | 920284 | Nut ¼-20 | 2 |
| 22 | 66694A | Plate Control Lever | 1 |
| 23 | 962481 | Screw ¼-20 x 1¼ | 2 |
| 24 | 980646 | Washer ¼ | 1 |
| 25 | 25602A | Lever Control | 1 |
| 26 | 66151A | Pivot Control Rod | 1 |
| 27 | 80021A | Bolt 3/8 x 5/8 | 1 |
| 28 | 85818A | Screw 5/16-18 x 2¼ Hex St | 1 |
| 29 | 21904C | Clamp - Handle | 1 |
| 30 | 64405A | Handle - Steering | 1 |
| 31 | 86200A | Screw - 3/8-16 Set St | 2 |
| 32 | 920110 | Nut 5/16 -18 ESNA | 2 |
| 33 | 20704C | Box - Switch | 1 |
| 34 | 85816A | Screw 5/16-18 x ¾ Hex St Flt Hd | 2 |
| 35 | 66114C | Pipe - Handle | 1 |
| 36 | 41917A | Cord - Interconnecting | 1 |
| 37 | 962288 | Screw 3/8-16 x 1" Hex St Cap | 3 |
| 38 | 21102C | Bracket - Handle | 1 |
| 39 | 62609A | Cover, Handle Bracket | 1 |
| 40 | 962016 | Screw 10-24 x ½ Pn St Mach | 2 |
| 41 | 170637 | Connector, Conduit | 1 |
| 42 | 980638 | Washer - 3/8 Diameter Lock | 3 |
| 43 | 41707A | Connector | 1 |
| 44 | 67144A | Rod Control | 1 |
| 45 | 920148 | Nut 3/8-16 Jam | 1 |
| 46 | 45608A | Plug (NEMA) | 1 |
| 47* | 962727 | Screw, 8-32 x ½ | 7 |
| 48* | 40675A | Cover Inlet | 1 |
| 49* | 920065 | Nut, #8 | 7 |
| 50* | 40674A | Cover, Switch | 1 |
| []# | 56380639 | Decal-Prop 65 | 1 |

[] = Not Shown

* NOTE: Part numbers 47, 48, 49 and 50 are for machine model #70120A only.

= Revised or new since last update

**Clarke®
American Sanders**
Model American 12 Floor Sander
Drawing #2 5/06

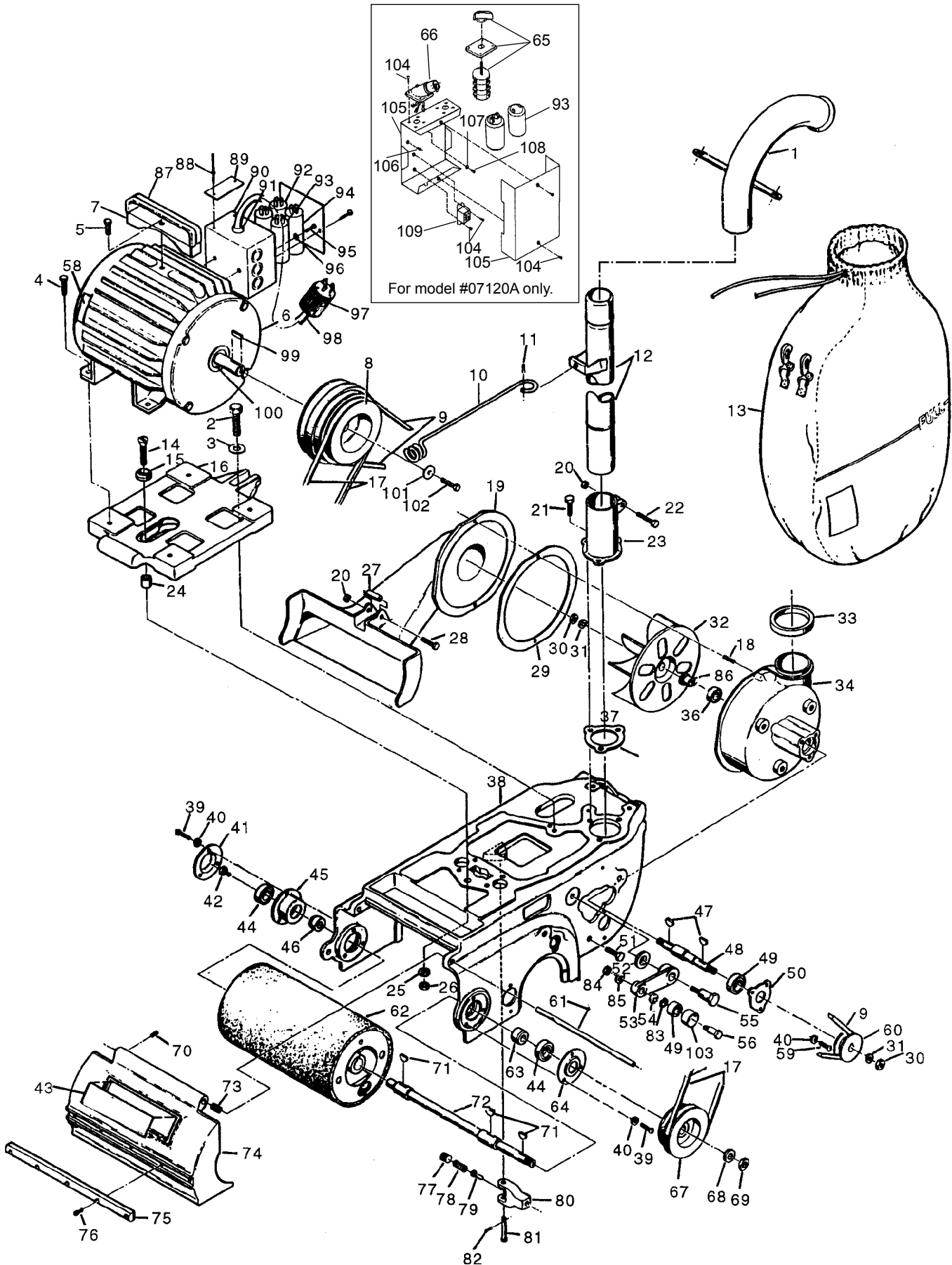

Clarke
American Sanders
Model American 12 Floor Sander
Parts List #2 5/06

| Ref # | Part No. | Description | Qty |
|-------|----------|--------------------------------------------|-----|
| 1 | 62800A | Pipe, Ass'y | 1 |
| 2 | 85714A | Screw, ½ - 13 x 2¼ Hex | 1 |
| 3 | 87006A | Washer, .56 X 1.38 X .11 Flat | 1 |
| 4 | 962216 | Screw 3/8 -16 x 1¼ Hex | 4 |
| 5 | 962870 | Screw 3/8-16 x 1 | 1 |
| 6 | 44639A | Motor 4 hp 230V/60 | 1 |
| | 44640A | Motor 3 hp 240V/50 | 1 |
| ◆ | 40746A | Motor 2.2 kW 230V/50 | 1 |
| 7 | 64460A | Handle, Motor | 1 |
| 8 | 66164A | Pulley, Motor | 1 |
| 9 | 51028A | Belt-V | 1 |
| 10 | 60401A | Arm, Cable | 1 |
| 11 | 925044 | Pin, 3/32 x 1 Cotter | 1 |
| 12 | 66110A | Pipe Assembly | 1 |
| 13 | 50954A | Dust Bag | 1 |
| 14 | 84220A | Screw, ½-13 x 2¼ Ft. | 1 |
| 15 | 68704A | Washer - Motor Screw | 1 |
| 16 | 26108C | Platform, Motor | 1 |
| 17 | 51021A | Belt - V | 1 |
| 18 | 68002A | Stud | 1 |
| 19 | 26102A | Pan, Dust | 1 |
| 20 | 920256 | Nut, 5/16-18 Hex | 2 |
| 21 | 85820A | Screw, 3/8-16 x 5/8 Hex | 3 |
| 22 | 85816A | Screw, 5/16-18 x 13/4 Hex | 1 |
| 23 | 27801C | Support, Dust Pipe | 1 |
| 24 | 67820A | Spacer, Motor Screw | 1 |
| 25 | 87101A | Washer, ½ Lock | 1 |
| 26 | 920196 | Nut, ½-13 Hex Jam | 1 |
| 27 | 30501A | Bushing | 1 |
| 28 | 85817A | Screw, 5/16-18 x 2" Hex | 1 |
| 29 | 34224A | Gasket | 1 |
| 30 | 81202A | Nut, 7/16-14 Hex L.H. | 2 |
| 31 | 87002A | Washer | 2 |
| 32 | 23300A | Fan | 1 |
| 33 | 39704A | Washer, Felt | 1 |
| 34 | 24504C | Housing, Fan | 1 |
| 36 | 902567 | Bearing | 1 |
| 37 | 34223A | Gasket, Support Pipe | 1 |
| 38 | 23406A | Frame | 1 |
| 39 | 962983 | Screw, ¼-20 x 5/8 Pan | 6 |
| NI | 18601A | Shaft Ass'y Drum includes D56, D39, D71 | (1) |
| 40 | 980657 | Washer, ¼ Lock | 9 |
| 41 | 62608C | Cover, Drum Housing | 1 |
| 42 | 67314A | Screw, Special | 1 |
| 43 | 70706A | Plate, Name CAS | 1 |
| 44 | 51110A | Bearing | 2 |
| 45 | 64703A | Housing, Bearing | 1 |
| 46 | 67818A | Spacer, Drum Shaft | 1 |
| 47 | 915028 | Key - #5 Woodruff | 2 |
| 48 | 67424A | Shaft Fan | 1 |
| 49 | 51111A | Bearing | 2 |
| 50 | 62001A | Cap, Bearing | 1 |
| 51 | 962288 | Screw, 3/8-16 x 1" Hex | 2 |
| 52 | 67816A | Spacer | 1 |
| 53 | 20401B | Arm | 1 |

| Ref # | Part No. | Description | Qty |
|-------|----------|-----------------------------------|-----|
| 54 | 67815A | Spacer, Idler Bearing | 1 |
| 55 | 68101A | Stud | 1 |
| 56 | 67413A | Shaft | 1 |
| 57 | 38109A | Seal, Dust Pipe (not illustrated) | 1 |
| 58 | 77234A | Label, Lifting Warning | 1 |
| 59 | 962823 | Screw, ¼-20 x ½ Pan | 3 |
| 60 | 66172A | Pulley, Fan Shaft | 1 |
| 61 | 67417A | Shaft, Drum Cover | 1 |
| 62 | 13500A | Drum Assembly | 1 |
| 63 | 67819A | Spacer, Drum Shaft | 1 |
| 64 | 66918A | Retainer, Bearing | 1 |
| 65◆ | 40676A | Switch, Control | 1 |
| 66◆ | 10603A | Inlet Assembly | 1 |
| 67 | 66165A | Pulley, Drum | 1 |
| 68 | 980644 | Washer, 5/8 Plain | 1 |
| 69 | 920280 | Nut, 5/8-18 Hex Jam | 1 |
| 70 | 962262 | Screw, 8-32 x ¼ Set | 1 |
| 71 | 55400A | Key - #9 Woodruff | 3 |
| 72 | 67415A | Shaft, Drum | 1 |
| 73 | 67911A | Spring | 1 |
| 74 | 22111A | Cover, Drum | 1 |
| 75 | 31211A | Bumper Assembly | 1 |
| 76 | 85517A | Screw, 10-24 x ½ PN | 5 |
| 77 | 86202A | Screw, Set 5/8-11 | 1 |
| 78 | 67908A | Spring | 1 |
| 79 | 66115A | Plunger | 1 |
| 80 | 29402A | Yoke | 1 |
| 81 | 66505A | Pin, Yoke | 1 |
| 82 | 925036 | Pin, 3/32 x 3/4 Cotter | 1 |
| 83 | 877304 | Ring Retaining | 1 |
| 84 | 920148 | Nut, 3/8-16 Hex Jam | 1 |
| 85 | 87000A | Washer | 1 |
| 86 | 61602A | Collar | 1 |
| 87 | 32357A | Cover Handle | 1 |
| 88 | 930087 | Rivet | 2 |
| 89 | 74044A | Plate Safety | 1 |
| 90 | 62904A | Enclosure Motor | 1 |
| 91 | 697502 | Strain Relief Bushing | 1 |
| 92 | 41305A | Capacitor, Start | 2 |
| 93 | 41304A | Capacitor, Run | 1 |
| 94 | 47378A | Switch, Start | 1 |
| 95 | 962823 | Screw, ¼-20 X ½ | 2 |
| 96 | 980614 | Washer | 2 |
| 97 | 45604A | Plug | 1 |
| 98 | 41945A | Cord, Motor | 1 |
| 99 | 915098 | Key, ¼ Sq. x 1¼ | 1 |
| 100 | 57712A | Ring, Retaining | 1 |
| 101 | 87034A | Retainer Pulley | 1 |
| 102 | 962288 | Screw, 3/8-16 x 1 | 1 |
| 103 | 66173A | Pulley Idler | 1 |
| 104◆ | 962727 | Screw, 8-32 x ½ | 8 |
| 105◆ | 61599A | Enclosure, Switch | 1 |
| 106◆ | 87700A | Screw, ¼-20 x ½ | 2 |
| 107◆ | 980603 | Washer | 1 |
| 108◆ | 85833A | Screw, 10-32 x 3/8 | 1 |
| 109◆ | 46323A | Relay | 1 |

Motor Parts Not Illustrated

| Part # | Description | Qty. |
|--------|-------------|------|
| 50563A | End Bell | 1 |
| 52768A | Front Cover | 1 |
| 53998A | Fan | 1 |
| 52769A | Fan Cover | 1 |

| Part # | Description | Qty. |
|--------|-------------------|------|
| 51188A | Bearing Front | 1 |
| 902547 | Bearing Rear | 1 |
| 40316A | Armature Assembly | 1 |

NOTE: ◆ indicates a change has been made since the last publication of this manual.

**Clarke®
American Sanders**
American 12 Floor Sander
Assembly Drawing #3 5/06

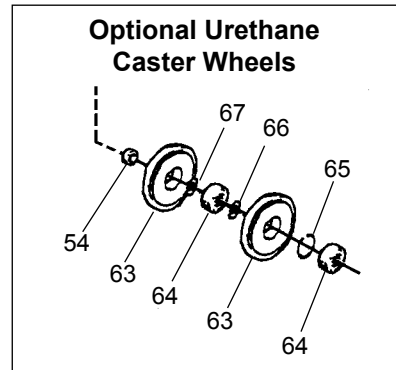
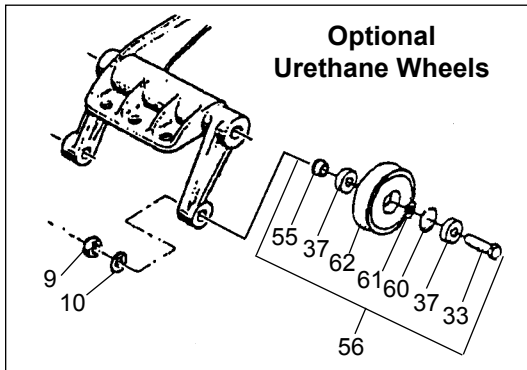
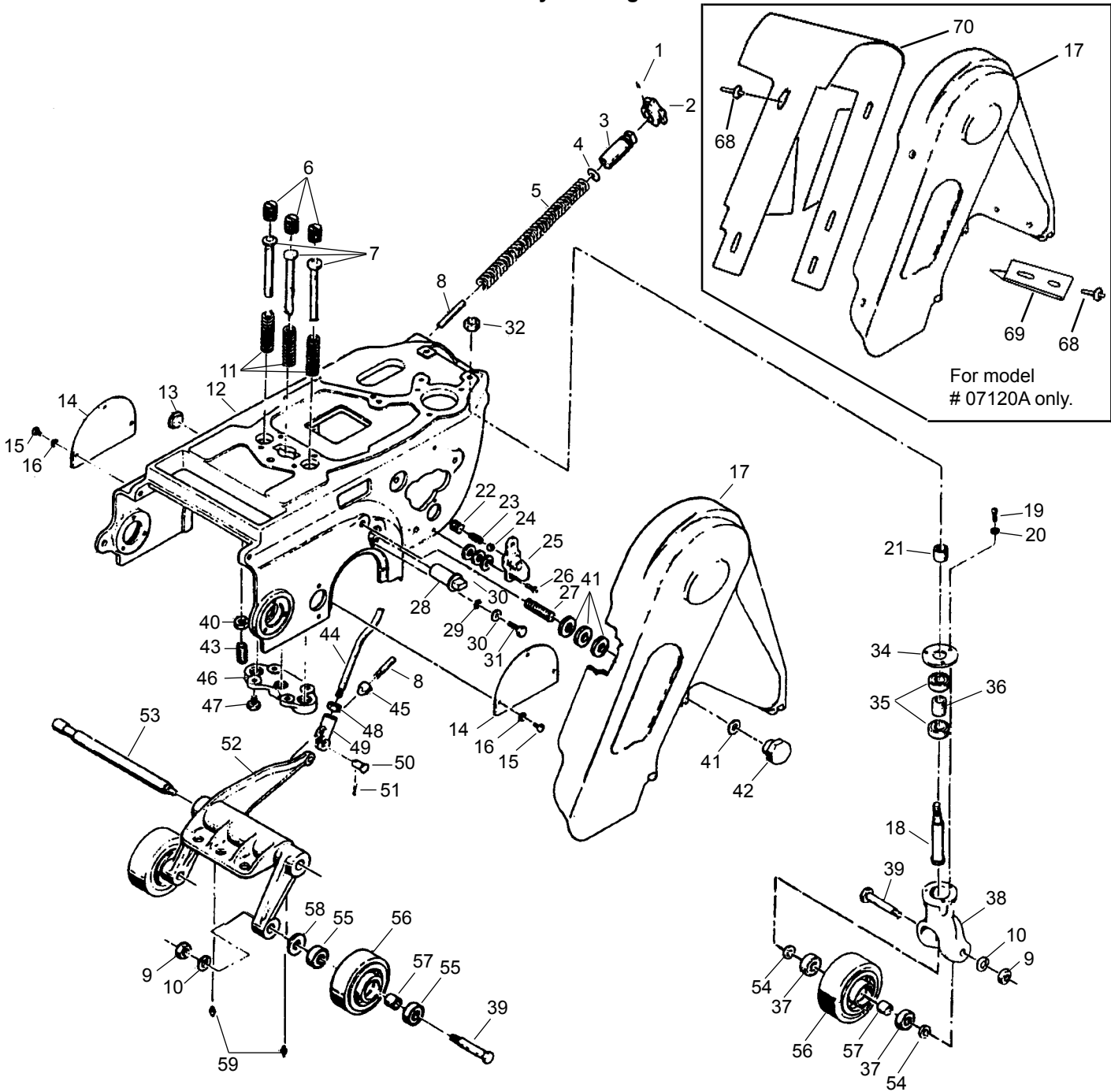

Clarke
American Sanders
American 12 Floor Sander
Assembly Parts List #3 5/06

07048C
07049C
07108A
07109A
07120A

| Ref. No | Part No. | Description | Qty | Qty | Qty |
|---------|----------|----------------------------------------------------------------------------------|------|------|------|
| 1 | 88502A | Screw, 10-24 x ³ / ₈ Set | 2 | 2 | 2 |
| 2 | 25200C | Knob, Hand | 1 | 1 | 1 |
| 3 | 67309A | Screw, Sustainer | 1 | 1 | 1 |
| 4 | 87000A | Washer | 1 | 1 | 1 |
| 5 | 67907A | Spring, Sustainer | 1 | 1 | 1 |
| 6 | 67315A | Screw | 3 | 3 | 3 |
| 7 | 66123A | Plunger, Spring | 3 | 3 | 3 |
| 8 | 67109A | Rod, Pilot | 1 | 1 | 1 |
| 9 | 920196 | Nut, 1/2-13 Hex Jam | 3 | 3 | 3 |
| 10 | 87101A | Washer, 1/2 Lock | 3 | 3 | 3 |
| 11 | 67906A | Spring | 3 | 3 | 3 |
| 12 | Ref. | Frame, Main | 1 | 1 | 1 |
| 13 | 57100A | Button, Plug | 1 | 1 | 1 |
| 14 | 66628C | Plate, Cover Wheel | 2 | 2 | 2 |
| 15 | 962015 | Screw, 10-24 x ³ / ₈ Pn St Mach | 6 | 8 | 6 |
| 16 | 980650 | Washer, ³ / ₁₆ Lock | 6 | 6 | 11 |
| 17 | 23801A | Guard, Belt | 1 | 1 | - |
| ◆ | 21097A | Guard, Belt | - | - | 1 |
| 18 | 60715B | Bolt, Pivot | 1 | 1 | 1 |
| 19 | 962823 | Screw, 1/4-20 x 1/2 Pn St Mach | 3 | 3 | 3 |
| 20 | 980657 | Washer, 1/2 Lock | 3 | 8 | 3 |
| 21 | 67814A | Spacer | 1 | 1 | 1 |
| 22 | 86202A | Screw, ⁵ / ₈ -11 x ⁵ / ₈ St | 2 | 2 | 2 |
| 23 | 67909A | Spring | 2 | 2 | 2 |
| 24 | 51113A | Ball, 1/2 Diameter | 2 | 2 | 2 |
| 25 | 21902C | Clamp | 2 | 2 | 2 |
| 26 | 962892 | Screw, 1/4-20 x ⁵ / ₈ Pn St Mach | 4 | 4 | 4 |
| 27 | 68001A | Stud, Belt Guard | 1 | 1 | 1 |
| 28 | 62801A | Shaft, Cont. Ecc. | 1 | 1 | 1 |
| 29 | 980614 | Washer, #1114 Shakeproof | 1 | 1 | 1 |
| 30 | 87007A | Washer, Cont. Shaft Ecc. | 13 | 13 | 13 |
| 31 | 85806A | Screw, 1/4-20 x 1 Hex St | 1 | 1 | 3 |
| 32 | 81209A | Nut, Large Flange 1/2-13 | 1 | 1 | 1 |
| 33 | 60547A | Axle | - | 2 | 1 |
| 34 | 66913A | Retainer, Bearing | 1 | 1 | 1 |
| 35 | 51112A | Bearing | 2 | 2 | 2 |
| 36 | 67821A | Spacer | 1 | 1 | 1 |
| 37 | 51225A | Bearing, Ball | 6 | 6 | 2 |
| 38 | 29403C | Yoke, Wheel | 1 | - | 1 |
| 39 | 60101A | Axle | 3 | 1 | 1 |
| 40 | 920160 | Nut, ⁵ / ₁₆ -18 Hex JAM | 1 | 1 | 1 |
| 41 | 87006A | Washer, ⁹ / ₁₆ x 1 ³ / ₈ x 10 | ref. | ref. | ref. |
| 42 | 26000C | Nut, Retaining | 1 | 1 | 1 |
| 43 | 86201A | Screw, ⁷ / ₁₆ -18 Set | 1 | 1 | 1 |
| 44 | 67144A | Rod, Control | 1 | 1 | 1 |
| 45 | 62000A | Nut, End | 1 | 1 | 1 |
| 46 | 26502A | Plate, Plunger | 1 | 1 | 1 |
| 47 | 85811A | Screw, ⁵ / ₁₆ -18 x ³ / ₄ Hex St Cap | 4 | 4 | 4 |
| 48 | 920260 | Nut, ⁷ / ₈ -16 Hex | 1 | 1 | 1 |
| 49 | 53917B | Fork, Control | 1 | 1 | 1 |
| 50 | 66503A | Pin, Fork | 1 | 1 | 1 |
| 51 | 925036 | Pin, ³ / ₃₂ x ³ / ₄ Cotter | 1 | 1 | 2 |
| 52 | 25600A | Lever, Reach | 1 | 1 | 1 |
| 53 | 67416A | Shaft, Lever | 1 | 1 | 1 |
| 54 | 67810A | Spacer | 2 | 2 | 2 |
| 55 | 60544A | Spacer | - | 2 | 1 |
| 56 | 59928A | Wheel (Steel) | 3 | - | - |
| | 10243A | Kit, Wheel (Urethane) (Optional) | - | - | - |
| 57 | 67817A | Spacer | 3 | 3 | 3 |
| 58 | 87003A | Washer | 2 | 2 | 2 |
| 59 | 54000A | Fitting, Grease | 2 | 2 | 2 |
| 60 | 167312 | Ring, Retainer | 2 | 2 | 2 |
| 61 | 60481A | Spacer | - | 2 | 1 |
| 62 | 50992A | Wheel, Assembly | - | 2 | 2 |
| 63 | 61333A | Wheel, Caster 4" | - | 2 | 2 |
| 64 | 51226A | Bearing | - | 4 | 4 |
| 65 | 747304 | Ring, Retaining | - | 2 | 2 |
| 66 | 87003A | Spacer | - | 1 | 1 |
| 67 | 61355A | Spacer | - | 2 | 2 |
| 68◆ | 930087 | Rivet | - | - | 7 |
| 69◆ | 61693A | Shield, Lower Guard | - | - | 1 |
| 70◆ | 61692A | Shield, Upper Guard | - | - | 1 |

NOTE: ◆ indicates a change has been made since the last publication of this manual.

Clarke®
American Sanders
American 12 Floor Sander
Accessories Drawing & Parts List #4 10/00

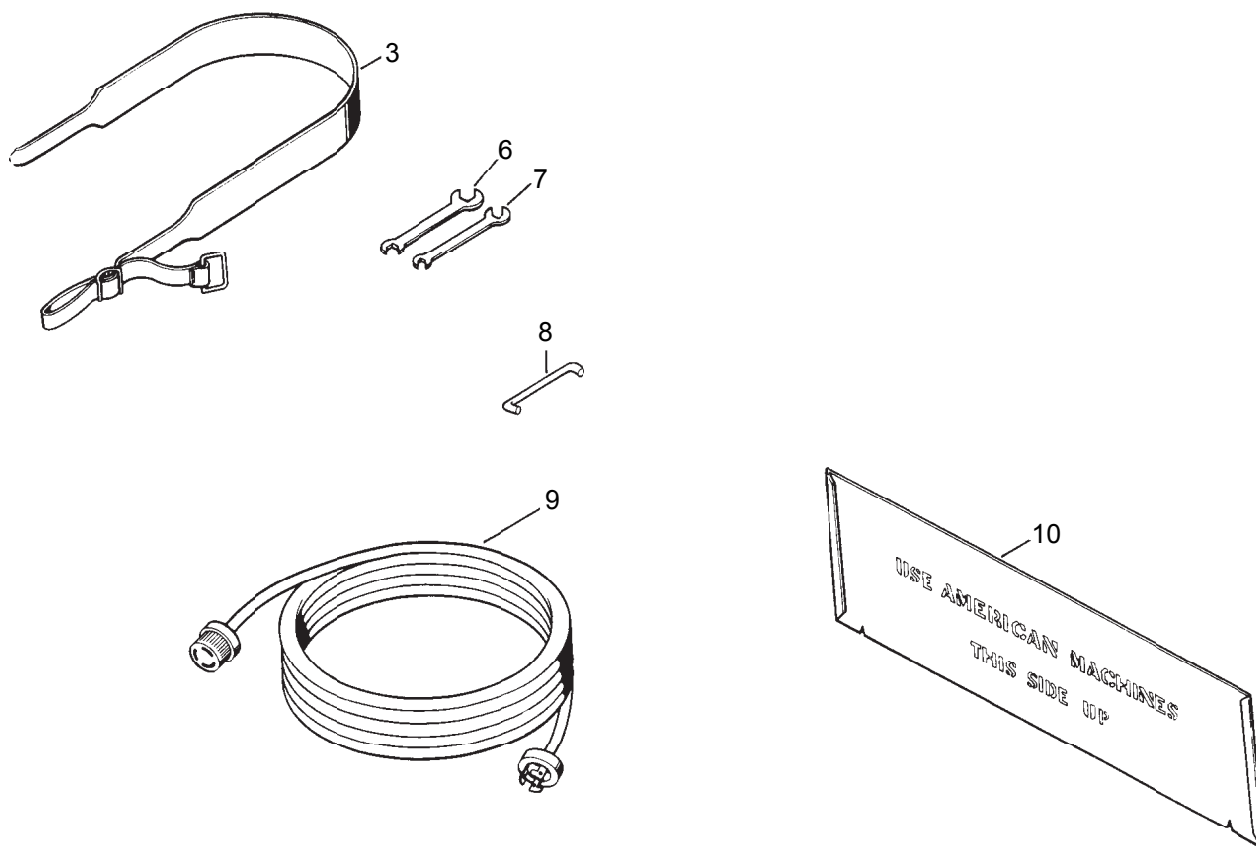

| Ref. # | Part No. | Description | Qty |
|--------|----------|------------------------|-----|
| 1 | | | |
| 2 | | | |
| 3 | 60724A | Belt, Operating | 1 |
| 5 | | | |
| 6 | 59810A | Wrench, Paper Clamp | 1 |
| 7 | 50842A | Wrench, End 3/4 x 7/16 | 1 |
| 8 | 64415A | Handle, Carrying | 1 |
| 9 | 42201A | Cord Assembly (NEMA) | 1 |
| | 42302A | Cordset, 240/50 | 1 |
| 10 | 68314A | Template | 1 |

Clarke
American Sanders
American Sander 12
Wiring Diagram 5/06 (models 07044C, 07049C, 07108A and 07109A)

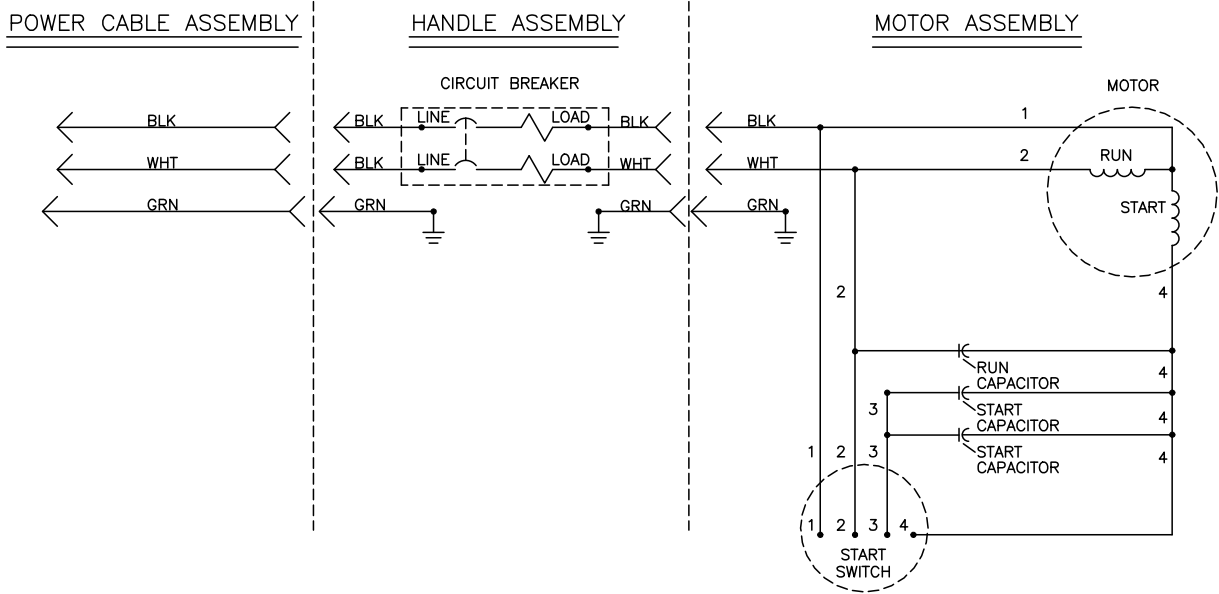

Clarke
American Sanders
American Sander 12
Wiring Diagram 5/06 (model 07120A)

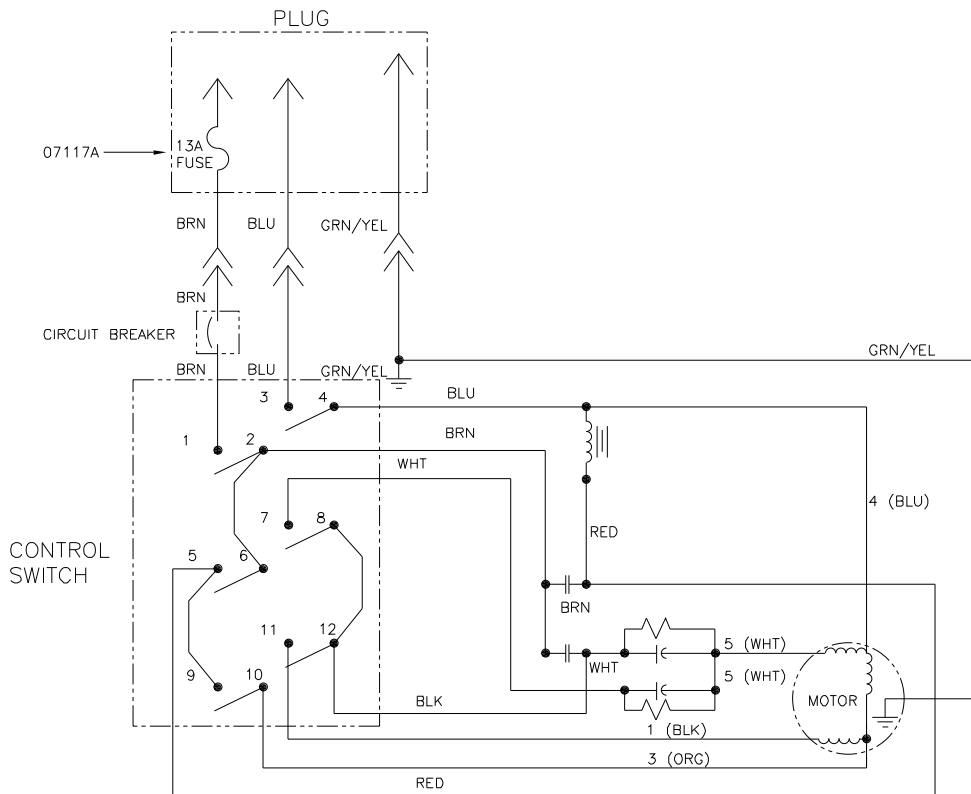

Chatter - Wave Prevention

Clarke American Sanders Sanders are designed and manufactured to the most rigid tolerances. However, after a finishing cut it is possible to see “chatter” or “waves”.

The best guarantee to remove the chatter is to finish the floor with a rotating horizontal sander, such as Clarke American Sanders’s Sander 16.

To minimize chatter when using a belt or drum sander the following steps should be taken:

- 1) **DRUM PAPER**...insure the paper is secured in the slot, but not too tight. Paper that is too tight will force the drum slot wider, leaving a “slot mark chatter” on the floor.

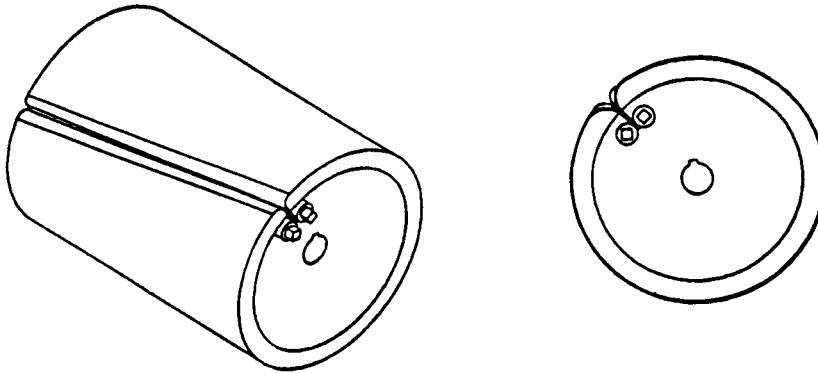

- 2) **DRUM MARKS**.....are caused by the operator lowering the drum to the floor without forward traverse. These marks should be removed by cutting at a 45 degree angle to the mark. Cutting at the mark while maintaining the same path will only increase the mark depth and width.

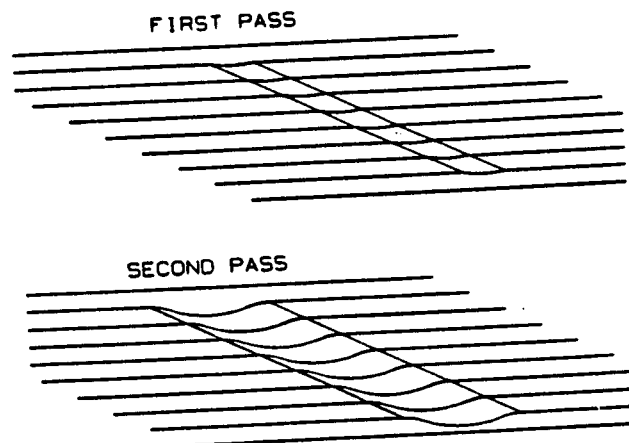

Chatter - Wave Prevention (cont)

- 3) UNEVEN WALKING PACE..... can leave lengthy “waves”. The machine cuts more material during the slower pace. Pay particular attention to a steady, even pace.
- 4) EXCESSIVE LIGHT CUTS.... may reveal high spots on the paper/contact wheel and cause chatter. Take a heavier cut and increase the pace.
- 5) DEBRIS.... lodged between the paper and the drum will leave chatter. On a belt sander, debris may be adhered to the drum. Insure the drum is clean and free of debris before placing the paper on.
- 6) SANDER PAPER QUALITY....may vary. Belt seams can be thicker on low quality paper and cause chatter. Use only Clarke American Sanders specified sandpaper.

PROPER CARE OF YOUR MACHINE CAN MINIMIZE CHATTER AND WAVES.

- 1) V-BELTS.... can cause vibration and chatter if they are of low quality. Use only belts specified by Clarke American Sanders.
- 2) TRUCK AND CASTER WHEELS....with flat spots, out-of-roundness, or debris adhered to their surface can cause “waves” or a “chatter effect”. Always clean and inspect all wheels before starting to sand, and before the finish cut. Replace or true the wheels if found to be out-of-round.
- 3) DUST PICK-UP SHOES.....may need adjusted differently for different materials that are to be sanded. An improperly adjusted shoe will leave trailing debris that will be run over by the wheels and cause “random waves”.
- 4) CONTACT WHEELS (DRUMS).....may be out-of-round and cause “chatter”. Contact your Clarke American Sanders dealer for assistance to true or replace the drum.
- 5) BEARINGS.....in the motor, drum, or fan system may become worn and induce vibration which could cause “chatter”.
- 6) PULLEYS....that are damaged or severely worn can induce vibration and cause “chatter”. Contact your Clarke American Sanders dealer for assistance.

Clarke American Sanders is not responsible for rework of floors that are unacceptable to the customer. It is your responsibility to insure your equipment is in proper operating order, and that you use the right machine for the job.

Clarke[®]
American Sanders[®]

14600 21st Avenue North
Plymouth, MN 55447-3408

www.clarkeus.com

Phone: 800-253-0367

Fax: 800-825-2753

©2010 Nilfisk-Advance, Inc.