

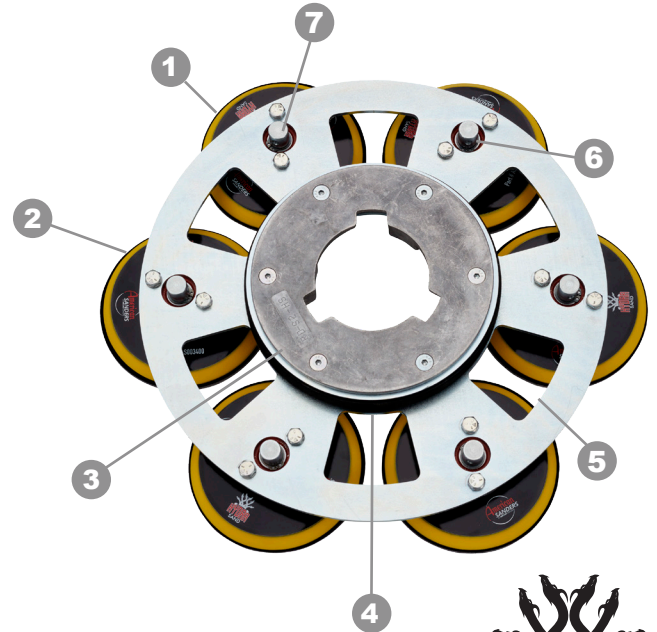

HYDRASAND

Multi Head Sanding Disc

- 1 Six 5" drive pads.
- 2 Backer pads provide smoother sanding, but may be removed to increase aggressiveness.
- 3 Strong, six-bolt clutch plate construction transfers torque without the use of plastic gear assembly.
- 4 Isolator/dampener provides superior handling.
- 5 Large air slots allow for premium dust collection.
- 6 Steel-encased bearings for added strength and performance.
- 7 The raised bearing shaft allows for quick, wrench-free, pad removal.



PRODUCT DESCRIPTION

The HydraSand attachment mounts to any rotary sander and utilizes six 5" pads mounted to a thick steel plate. The six sanding pads provide maximum sanding performance and longer runs between abrasive changes. HydraSand is 15% more productive than leading competitive units.

RECOMMENDED PRODUCTS



The HydraSand attachment mounts to any standard rotary sander. There is no need to purchase a special machine to use the HydraSand.

TECHNICAL DATA

Pad Size 5"

Driver Construction Steel

Weight 12 lb (5.4 kg)

Warranty Parts & Labor - 6 months*
*Excludes consumable wear items

Specifications are subject to change without notice.

AVAILABLE MODELS

SA031600 - HydraSand



16" HYDRASAND ASSEMBLY

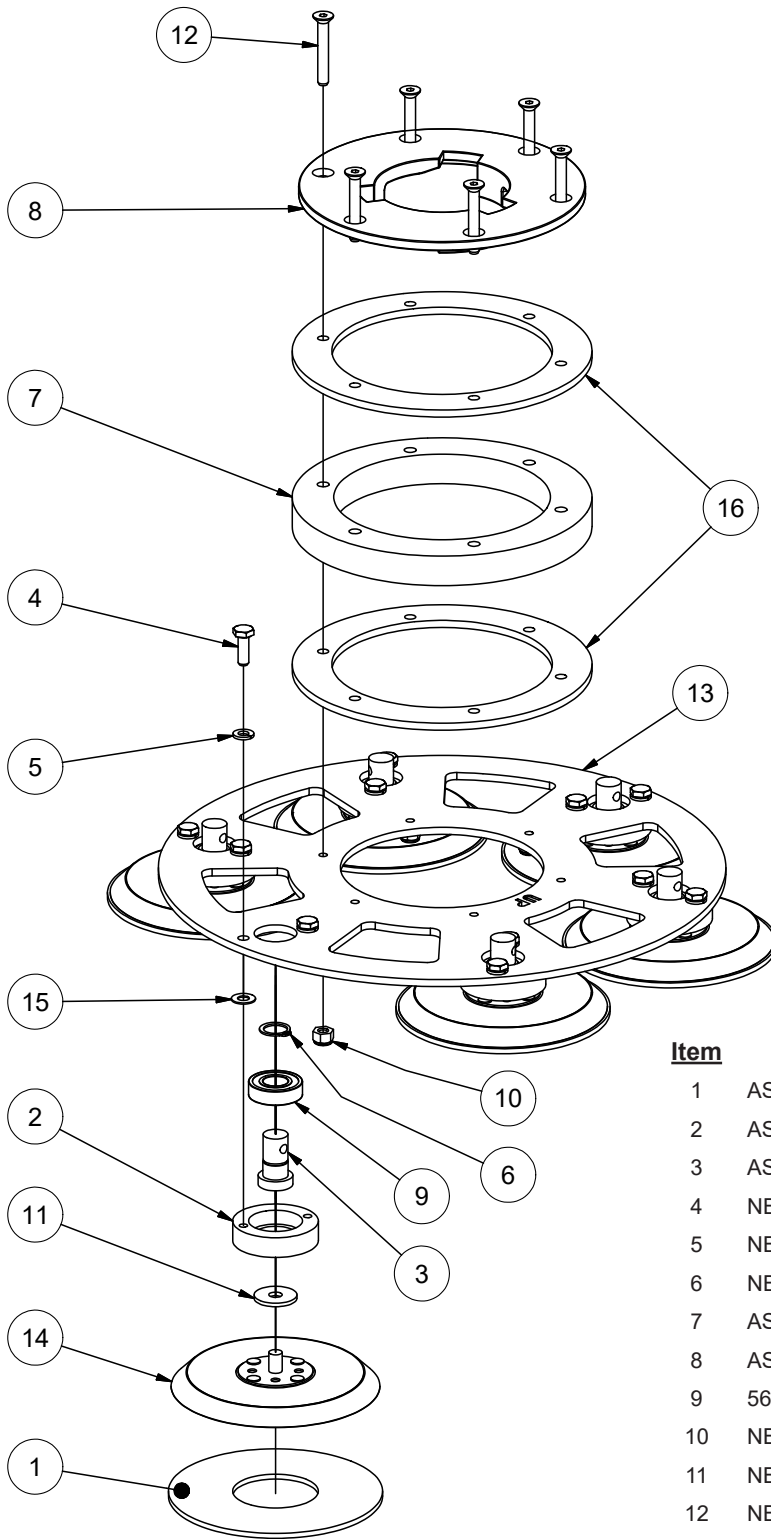

<u>Item</u>	<u>Ref. No.</u>	<u>Description</u>	<u>Qty</u>
1	AS003500	PAD, FOAM, 5"	6
2	AS003700	HOUSING, BEARING, DRIVER	6
3	AS003800	SHAFT, DRIVER	6
4	NB019100	BOLT, HEX, 1/4" X 3/4", GD 5	12
5	NB6110	WASHER, LOCK, 1/4"	12
6	NB070200	RING, RETAINING, EXT	6
7	AS004800	RING, ISOLATOR	1
8	AS004600	PLATE, CLUTCH, DRIVER	1
9	56380282	BEARING-BALL, 6002 CUSTOM	6
10	NB3275	NUT, LOCK, 1/4"	6
11	NB080100	WASHER .312 X 1 X .0840-.0960	6
12	NB071300	SCREW, SOCKET, FLAT, CS 1/4-20 X 2" SS	6
13	AS003600	PLATE, DRIVER	1
14	AS003400	PAD, DRIVER, 5", ASM.	6
15	NB071400	WASHER, GROUND, 1/4"	6
16	AS004700	RING, SPACER	2